

BEAM BUG III

Reduces Material Handling, Cut Beams,
Channels And Angles In Place.



Bug-O Systems
Affordable Track Cutting and
Welding Systems.

www.bugo.com



BEAM BUG III

The BEAM BUG III is a lightweight, easy to carry machine designed to cut beams, channels and angles from one rail setting. It produces smooth, square, accurate cuts and virtually eliminates grinding and touch-up. Now, you can take the machine to the work and greatly reduce material handling costs.

The BEAM BUG III is positioned on the workpiece by placing the beam rail on top of the beam. This rail is held in position by powerful permanent magnets and beam clamps. The beam rails enable miter cuts on webs, and when the work can be positioned, on the flanges too.

The BEAM BUG III carriage has a push-button clutch and locks onto the beam rail. It is easily removed for handling

and/or storage. A single speed control sets both vertical and horizontal travel speed. Movement in either direction is selected by a toggle switch. Positive rack and pinion drives with infinitely variable speed control insure precise cutting speeds. Limit switches prevent vertical (flange rail) overrun. Gases are controlled by a quick-acting manifold which eliminates repetitive torch adjustment. Double-bearing wheels provide rigidity and accuracy. The torchholder and torch, swivel to the correct position and positioning pins set bevel angles. The BEAM BUG III is supplied with a 10" (254 mm) two-hose machine torch and three cutting tips. (Specify fuel gas and voltage when ordering.)

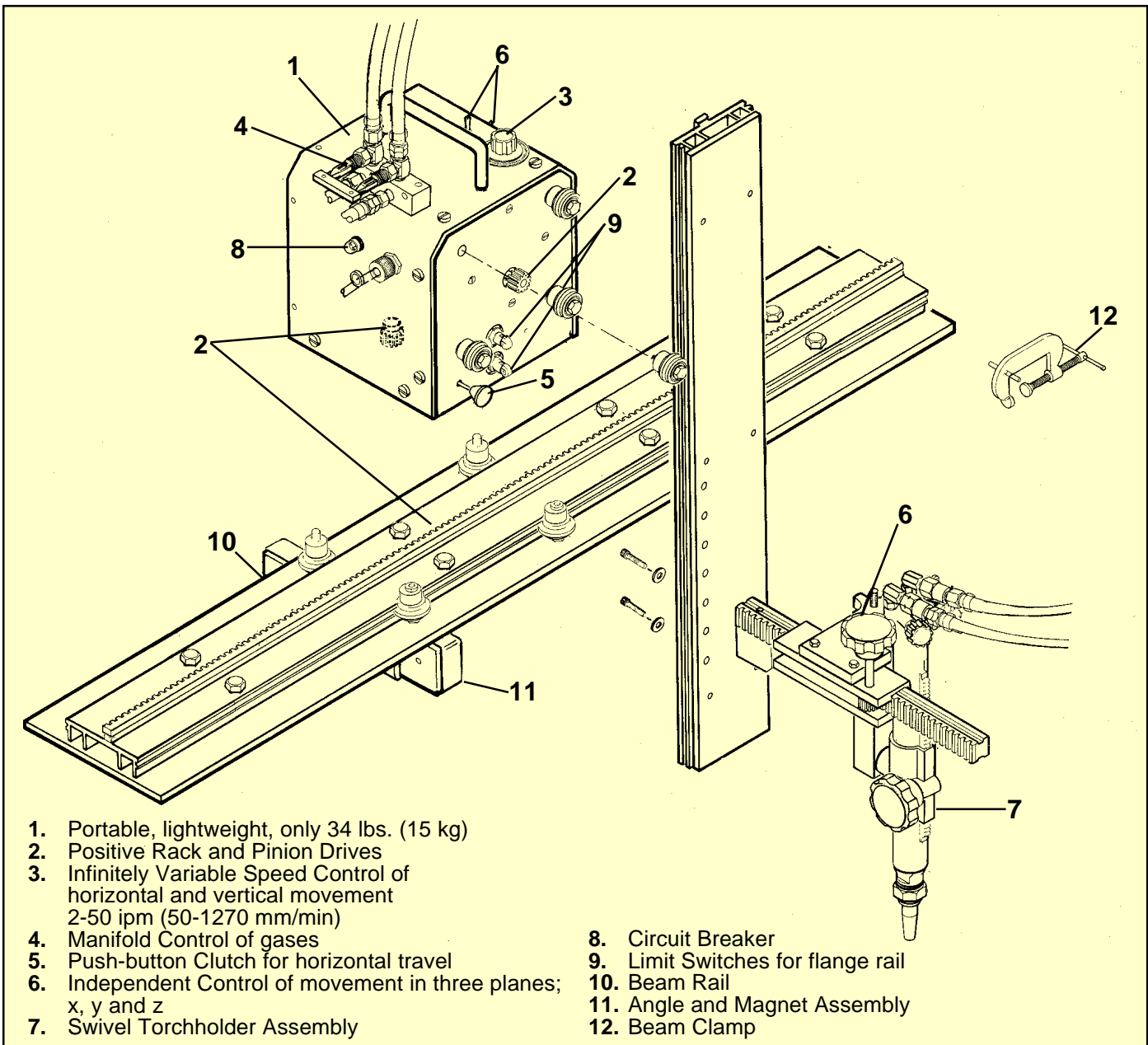



BEAM BUG III

Technical Data:

Travel Speeds: 2-50 ipm (50 - 1270 mm/min)

Flange: 22" (560 mm)

Dimensions: 10"L x 10.50"W x 12.38"H
(254 mm x 267 mm x 314 mm)

Net Weight: W/O TORCH & TIPS 34 lbs (15.4 kg)
W/TORCH & TIPS 38 LBS (17.2 kg)

Shipping Weight: W/O TORCH & TIPS 41 lbs (18.6 kg)
W/TORCH & TIPS 45 LBS (20.4 kg)

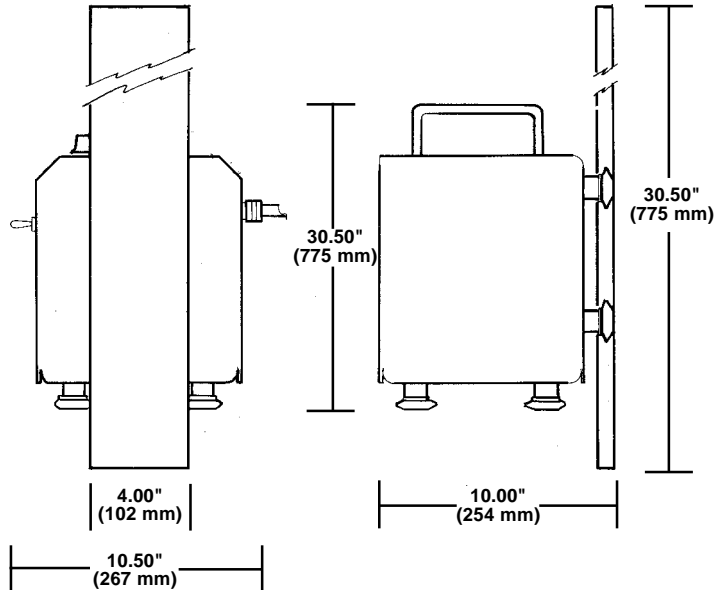

NOTE: The BEAM BUG III must be used with one of the beam rails described on the next page.

HOW IT WORKS:

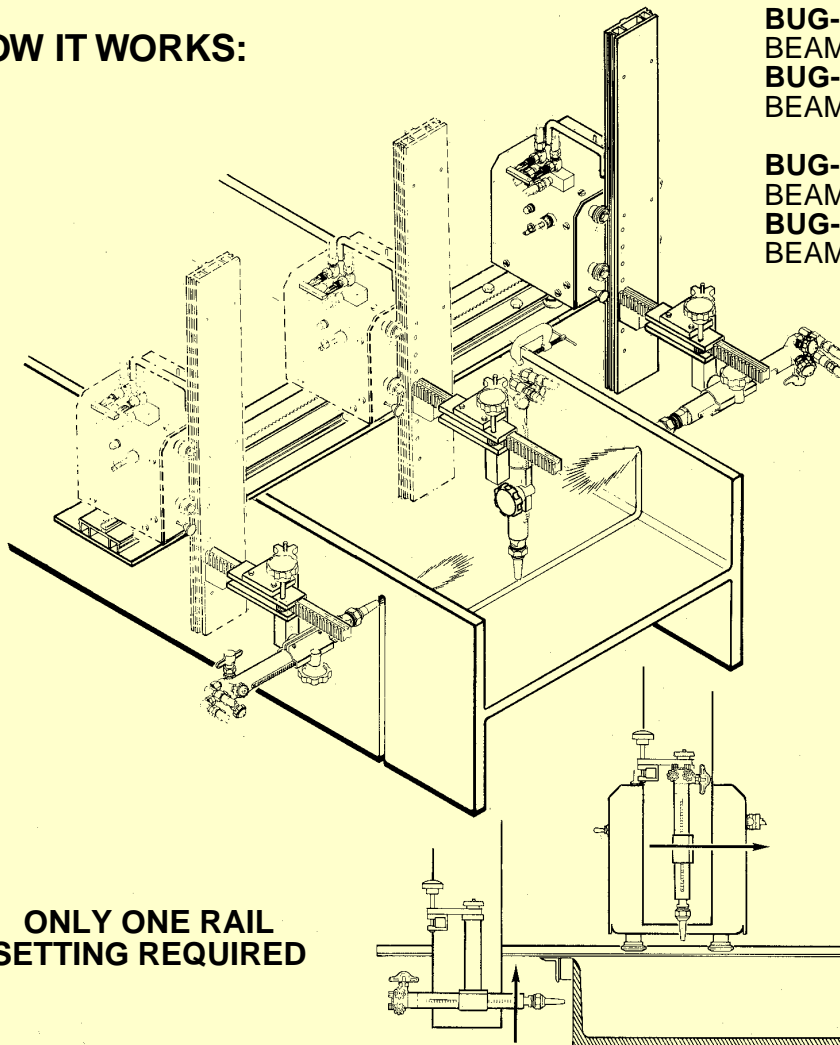

ONLY ONE RAIL SETTING REQUIRED

- BUG-1490-ACET**
BEAM BUG III 120 VAC ACETYLENE
- BUG-1490-PROP**
BEAM BUG III 120 VAC PROPANE
- BUG-1492-ACET**
BEAM BUG II 240 VAC ACETYLENE
- BUG-1492-PROP**
BEAM BUG II 240 VAC PROPANE



BEAM BUG III

ARR-9114
ARR-9214
ARR-9236

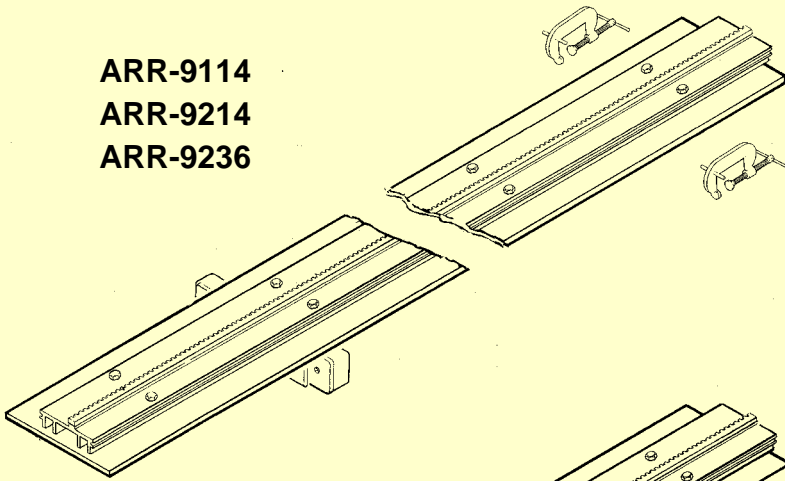

ARR-9120

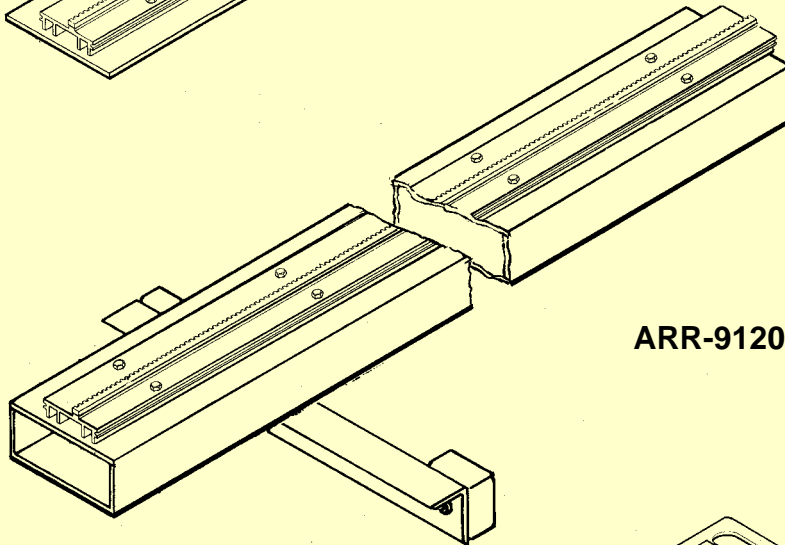

ARR-9045
ARR-9046

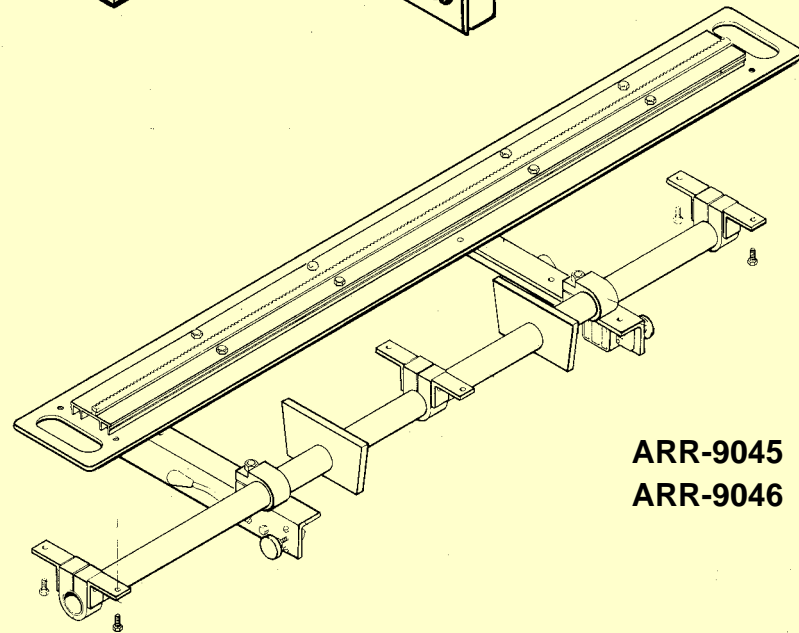

ARR-9114 BEAM RAIL

for square cutting beams ONLY.

Capacity: Cuts 2"-18" (50-450 mm) flanges and 14" (350 mm) webs

Length: 46 1/2" (1180 mm)

Net Weight: 18 lbs (8 Kg)

Shipping Weight: 28 lbs (13 kg)

ARR-9214 SWIVEL MOUNTED BEAM RAIL

for straight, bevel, coping and miter cuts on the web – may also be used for miter cuts on the flanges by rotating the beam.

Capacity: Cuts 2"-18" (50-450 mm) flanges and 36" (900 mm) webs

Miter Cuts On: 14" (350 mm) webs

Length: 72" (1830 mm)

Net Weight: 28 lbs (13 kg)

Shipping Weight: 41 lbs (18 kg)

ARR-9236 SWIVEL MOUNTED BEAM RAIL

same as above but, with greater capacity.

Capacity: Cuts 2"-18" (50-450 mm) flanges and 66" (1675 mm) webs

Miter Cuts On: 36" (900 mm) webs

Length: 102" (2590 mm)

Net Weight: 36 lbs (16 kg)

Shipping Weight: 51 lbs (23 kg)

ARR-9120 SWIVEL MOUNTED BEAM RAIL

same as above but, with greater capacity.

Capacity: Cuts 2"-18" (50-450 mm) flanges and 120" (3050 mm) webs

Miter Cuts On: 72" webs (1830 mm)

Length: 150" (3810 mm)

Net Weight: 62 lbs (28 kg)

Shipping Weight: 94 lbs (43 kg)

ARR-9045 ADJUSTABLE BEAM RAIL

includes two squaring bars and adjustable locks for miter cuts on webs and flanges-36" (915 mm) of travel.

Miter Cuts Flanges: 0°-45° to 14" (350 mm) wide

Miter Cuts Webs: 0°-13° to 36" (915 mm) wide
0°-45° to 24" (610 mm) wide

Length: 65" (1651 mm)

Net Weight: 50 lbs (23 kg)

Shipping Weight: 75 lbs (34 kg)

ARR-9046 ADJUSTABLE BEAM RAIL

includes two squaring bars and adjustable locks for miter cuts on webs and flanges -36" (915 mm) of travel.

Miter Cuts Flanges: 0°-45° to 14" (350 mm) wide

Miter Cuts Webs: 0°-34° to 60" (1524 mm) wide
0°-45° to 50"

Length: 102" (2590 mm)

Net Weight: 65 lbs (30 kg)

Shipping Weight: 90 lbs (41 kg)